

Installation Instructions for AOXVBLL06_43-A-A20 & AOXVBLL06_43-AT0

1- PACKAGE CONTENTS

Please find the following products inside the box:

- Antenna
- Mounting Kit
- ACU (Only for AOXVBLL06_43-A-A20)

2- RECOMMENDED TOOLS

The following tools are needed for proper installation:

- 8 mm Socket or Wrench for clamp tightening
- 13 mm Socket or Wrench for ground nuts
- Torque Wrench
- 19 mm Socket or Wrench for clamp tightening
- Phillips screwdriver --- For ACU mounting in AOXVBLL06_43-A-A20
- Allen wrench (hex key) of 5mm --- For manual overdrive in AOXVBLL06_43-AT0

3- ANTENNA POLE MOUNT

Mounting kit list

Item	Description	Qty.
1	Outer mounting bracket	1
2	Pole mounting clamp front	2
3	Pole mounting clamp rear	2
4	M12x185 screw	4
5	Flatten washer for M12 screw	4
6	Spring washer for M12 screw	4
7	M12 nut	4
8	Sealing rubber	4
9	M8x25 screw with washers	4
10	Flatten washer for M8 screw	4
11	Spring washer for M8 screw	4
12	nut NYH M8 SS 304 PVRO DIN 985	8

Assemble step

1. Assemble item 2 to item 1 by M8 screw, washer and nut (with 11Nm / 8 ft-lbs torque).

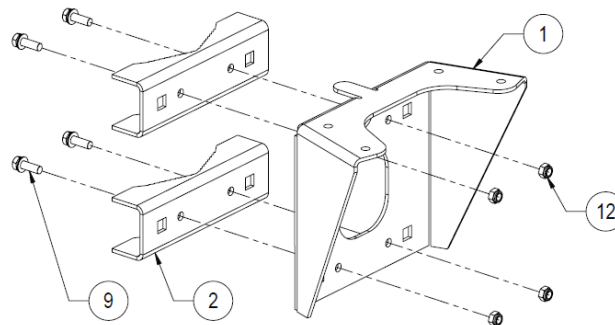

2. Assemble above sub-unit and item 8 to antenna by M8 washer and nut (with 11Nm / 8 ft-lbs torque). **NOTE: The convex steeliness ring on item 8 MUST be inserted to end plate of antenna.**

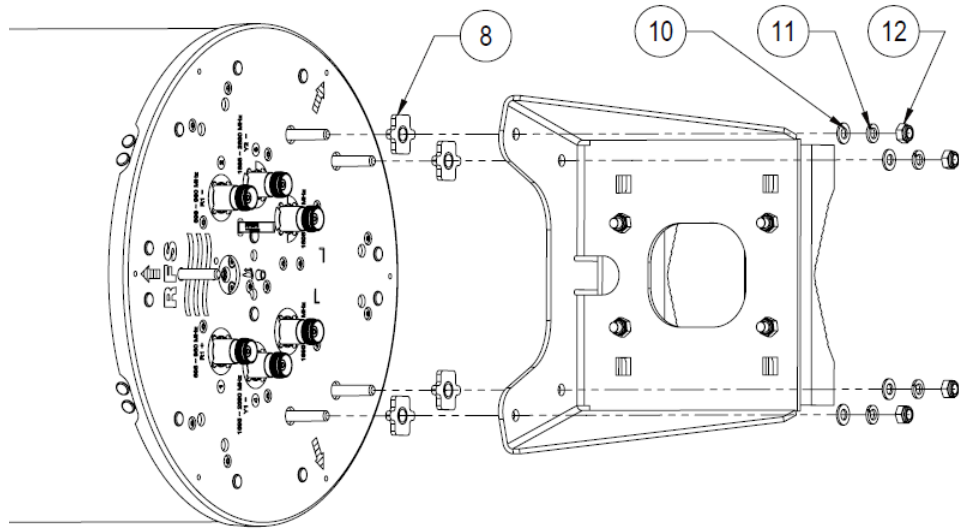

3. Connect item 3 to above sub-assembly by M12 screw, washer and nut (No need to tight).

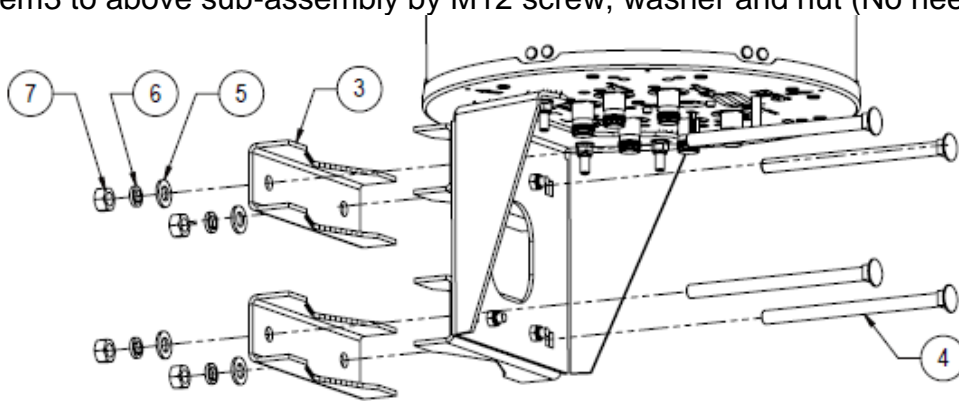

4. Insert the full assembly to pole and tight M12 nut with 40 Nm / 30 ft-lbs torque.

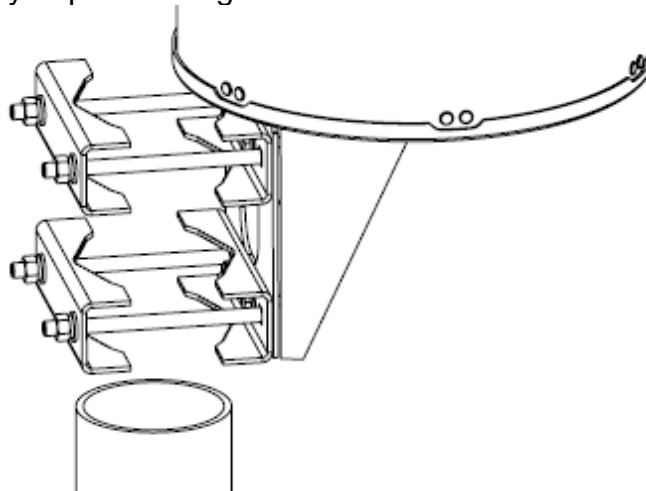

5. Connect the Antenna to the system by means of jumpers.
6. When attaching the jumper cable 4.3-10 connector coupling nut to the antenna 4.3-10 female connector it is mandatory that the jumper cable meet the 4.3-10 female connector of the antenna straight in line
7. Press the inner part of the jumper cable connector into the antenna connector and maintain this pressure when turning the jumper coupling nut. Once aligned, the jumper coupling nut will fit the thread of the female connector correctly and it will turn smoothly. Tighten the jumper coupling nut by hand.
8. Use a torque wrench to tighten the connector assembly with 11 Nm /8 ft-lbs torque. The torque wrench must be perpendicular to the antenna connector flange and jumper cable connector coupling nut when tightening. Note: No angular torque from the jumper cable is allowed at any time.
9. For additional protection against harsh environmental conditions, insulate all connector connections. See the Connector Insulation Section.

Read 10~12 for AOXVBLL06_43-A-A20:

10. Mount ACU to antenna with 2.4 Nm /1.8 ft-lbs torque.

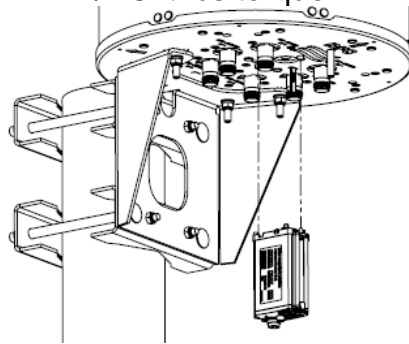

11. Connect AISG cable to ACU, the connector shall be fully tightened hand tight (0.6~1.0 Nm).
12. All unused AISG connectors shall be sealed with a connector sealing cap (provided with the ACU).

Read 13~14 for AOXVBLL06_43-AT0:

13. Insert hex key in the dedicated hole on end-cap shown as below (Pushing force < 5kg).

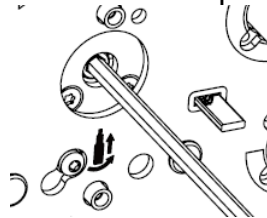

14. Rotate the hex key to manually adjust the electrical tilt (Torque < 0.45 Nm. Battery screwdriver or drill is **PROHIBITED**).

4- JUMPER CONNECTION DETAIL

The torque wrench must be perpendicular to the antenna connector flange and jumper cable connector coupling nut when tightening.

Note: No angular torque from the jumper cable is allowed at any time. Fluctuation between the antenna and the jumper axes < $\pm 2.5^\circ$

5- CONNECTOR INSULATION

For additional protection against harsh environmental conditions, connector connections may be insulated using weather sealant.

This insulation is performed after all 4.3-10 connector coupling nuts have been tightened as specified in the instructions.

RFS offers a variety of solutions that can withstand extreme weather temperatures and conditions, offer UV protection and are available in a variety of colors for easy tower-top cable identification. Contact a sales representative for ordering information.

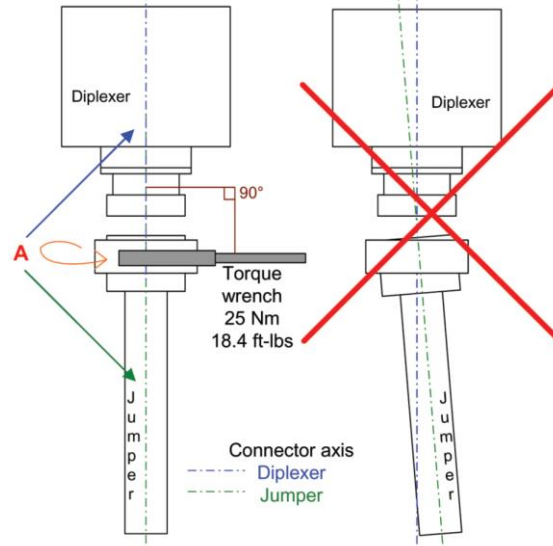

6- Outer size (Unit: mm)

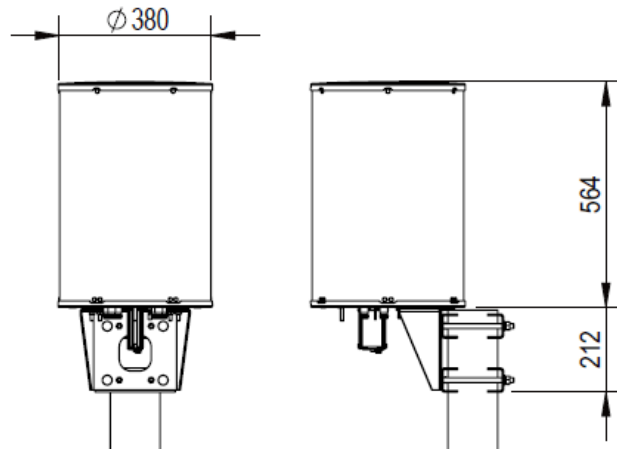

7- Tightening Torque Values

Unless otherwise stated, the following general tightening torque values shall be used for metric hexagon bolts and screws, coarse pitch threads, property class 4.6.

Dia.	Pitch (mm)	Bolt Tension (KN)	Torque (Nm)
M12	1.75	12.0	40
M8	1.25	7	11

8- Maintenance

Under normal conditions, no maintenance is necessary. However, the antenna should be visually inspected at regular intervals for damage (e.g.: due to lightning strikes, falling ice, etc.). Periodic checks should be performed to verify correct torque and bracket clearance settings.